

MODEL	TYPE	cap. (kg)	Car speed (m/s)	sheave (mm)	ropes (n)	rope size (mm)	pitch (mm)	current (A)	RPM	freq. (HZ)	Power (KW)	Torque (Nm)	shaft load (kg)	DIMENTION(mm)																
														weight (kg)	A	B	C	D	E	F	G	H	H1	H2	H3	L	L1	L2	M	N
WYT-T	1.0A	450	1	400	4	10	16	7.7	96	16	3.2	320	2500	300	140	195	47.5	29.5	320	385	420	270	497	540	605	510	580	800	56	30
	1.0B	630	1	400	4	10	16	10.4	96	16	4.6	460																		
	1.6B	630	1.6	400	4	10	16	15.9	153	26	7.4	460																		
	1.6C	800	1.6	400	5	10	16	19.8	153	26	8.8	550	3500	330	170	225	47.5	29.5	350	410										
	1.0D	1000	1	400	5	10	16	14.9	96	16	6.7	665																		
	1.6D	1000	1.6	400	5	10	16	24.6	153	26	10.7	665																		
	2.0D	1000	2	400	5	10	16	29.6	192	32	13.4	665																		

General specification	
Voltage	AC380V
Roping	2:01
Wrap	SINGEL
Protection class	IP41
Ins. Class	F
Pole	20
Rating	S5-40%
S/h	240
Max height	90m
Brake voltage	DC110V
Groove detail	
β(undercut angle)	97°
γ(groove angle)	25°

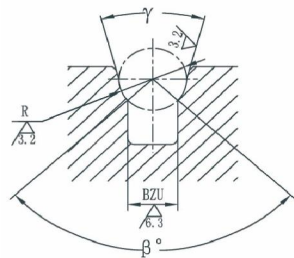

单绕槽型  
(Single groove)

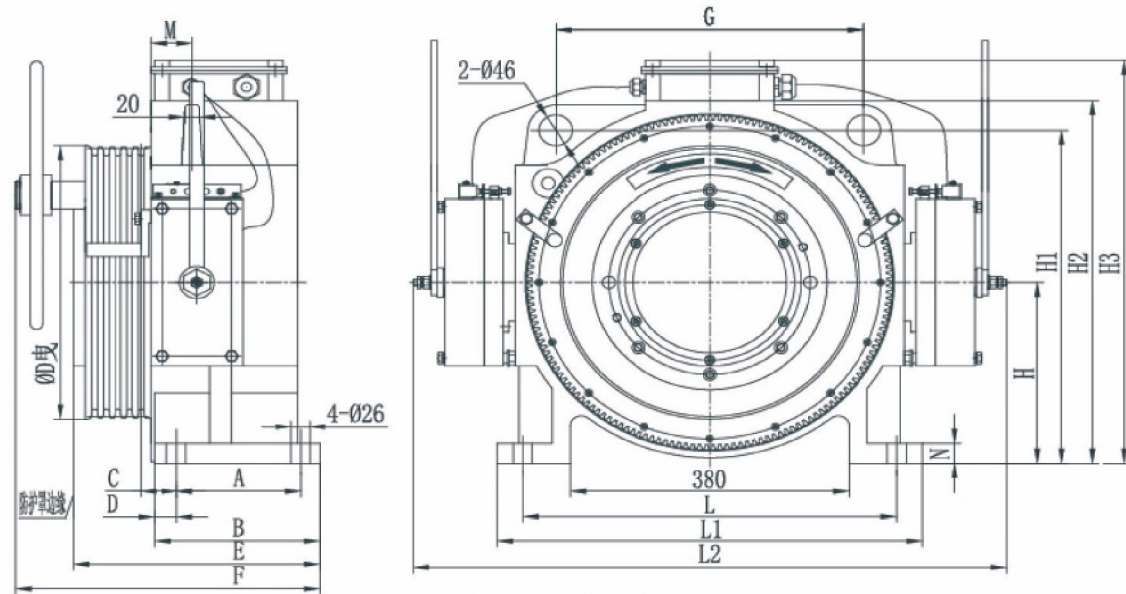

外观尺寸图 | Outline drawing